

# MAGIS

360° by Konstantin Grcic



# Konstantin Grcic



## Profile:

Konstantin Grcic ( born in 1965) was trained as a cabinet maker at the John Makepeace School for Craftsmen in Wood before studying Design at the Royal College of Art in London. Since setting up his own practice in 1991, he has developed furniture, products and lighting for leading design companies. Today, Konstantin Grcic Design is based in Berlin and is active in several fields ranging from industrial design projects, exhibition design and collaborations in architecture and fashion.

Among his industrial producers are Flos, Laufen, Magis, Muji, Nespresso, and Vitra. In the fashion and lifestyle sector his clients are a.o. Audi, Hugo Boss, Issey Miyake, Prada, Rado and smart/Daimler. Many of his products have been awarded international design prizes. He received the Compasso d'Oro in 2001 for the Mayday lamp (Flos), in 2011 for the Myto chair (Plank) and in 2016 for the OK lamp (Flos). For Tom and Jerry from Magis' series The Wild Bunch he received the German Design Award in Gold in 2011.

The world's most important design

museums (including MoMA, New York, Centre Pompidou, Paris, and Die Neue Sammlung, Munich) have included his designs in their permanent collections. The Royal Society for the Encouragement of Arts, Manufactures and Commerce (RSA) in England admitted Konstantin Grcic to the circle of Royal Designers for Industry in 2009 and in 2010 he was a fellow of the Villa Massimo in Rome. In 2016, Konstantin Grcic was honoured by the jury of the German Design Award with the Personality Award.

From 2020 to 2024 Grcic held a professorship at the Hamburg University of Fine Arts and has since been Honorary Professor. He has been appointed member of the Academy of Arts, Berlin in 2021 and of the Academy the Fine Arts, Munich in 2022.

Grcic defines function in human terms, combining formal strictness with considerable mental acuity and humour. His work is characterised by careful research into the history of art, design and architecture and his passion for technology and materials.



# Design and

The 360° collection consists of a chair, a table and two containers on wheels, which open the way to a new concept of office work.

The chair 360° is unconventional or it would be better not to call it chair at all, as it certainly has little to do with the common idea of chair.

360° is, in fact, neither a stool nor a chair, but something in-between.

Its name implies that it swivels around and that one can sit on it in all directions.

360° is not intended for long stints of work in a static position, but it encourages a form of dynamic sitting, short term, ad hoc, improvised - moving around.

Therefore, it can be considered as a forerunner of the office chair of the future.



# Engineering



“ Its name im-  
plies that it swi-  
vels around and



that one can sit  
on it in all di-  
rections.”

# Information



# Product

## SWIVEL CHAIR ON 5 WHEELS

Adjustable in height with gas piston. Frame in steel painted in epoxy resin. Foot-rest in die-cast aluminium. Seat in integral self-bearing polyurethane.

## TABLE Ø 140

Adjustable in height. Base in die-cast aluminium. Frame in aluminium. Crosspiece in steel. Top in steel sheet painted in polyester powder.

## DRAWER UNITS ON WHEELS 5 OR 10 DRAWERS

In glossy ABS, including one tray. Joining tube in stainless steel.

## CHAIR



Black 1764 C

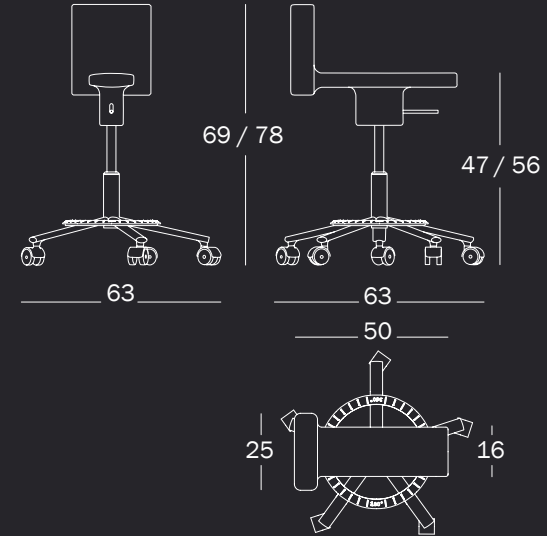

### PRODUCT CARE

Clean the product using a soft rag, either dry or wet. When needed, use ph-balanced soap diluted in water. Do not use abrasive sponges as they may leave scratches. Immediately dry after washing with a soft rag or a chamois leather. Avoid use of alcohol, solvents and products containing even a small quantity of ammonia. Periodic and correct maintenance allows the product to keep its original aspect and lengthens the duration of its performance.

### WARNING

ONLY SKILLED WORKERS ARE AUTHORISED TO REPLACE OR REPAIR THE COMPONENTS OF THE HEIGHT REGULATION SYSTEM. Do not use the product in an improper way: do not use different cleaning products from the ones mentioned above; do not place hot objects on it, sit on the back and/or on the arm, stand on it or use the product as a ladder. Once disused, please make sure that this product is disposed in an environment-friendly way.



## TABLE Ø 140

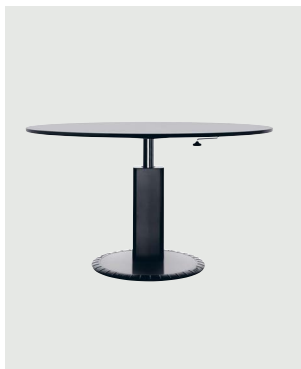

Frame in aluminium / Black 1764 C  
Top in steel sheet / Black 1764 C

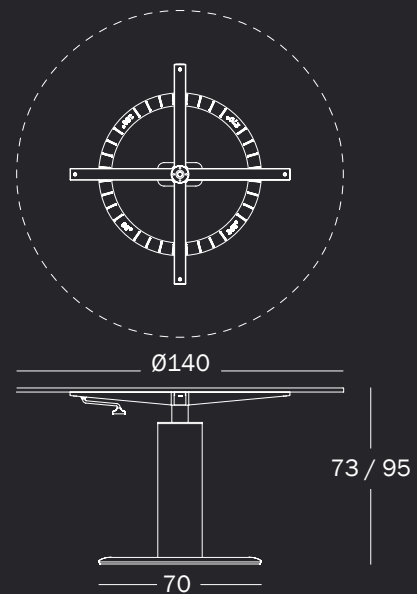

### PRODUCT CARE

We recommend using a soft rag, either dry or wet. When needed, use ph-balanced soap diluted in water. Do not use abrasive sponges as they may leave scratches. Avoid using acidic products, solvents and products containing ammonia. Periodic maintenance and cleaning allows the product to keep its original look and lengthens the duration of its performance.

### WARNING

Do not use different cleaning products from the ones mentioned above. Do not use the product in an improper way. Do not place hot objects on it, stand on it or use the product as a ladder. Once disused, please make sure this product is disposed in an environment-friendly way.

DRAWER UNITS ON WHEELS (5 Drawers)

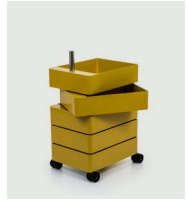

Yellow 1018 C

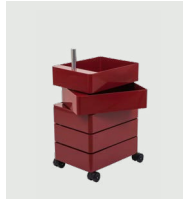

Bordeaux 1130 C



Blue 1234 C



Green 1321 C



Pink 1630 C



White 1673 C



Light grey 1707 C



Black 1764 C



Magenta 1834 C



Bright blue 1833 C



Bright yellow 1832 C

DRAWER UNITS ON WHEELS (10 Drawers)



Yellow 1018 C

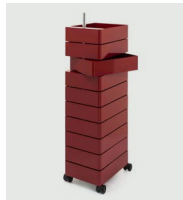

Bordeaux 1130 C



Blue 1234 C



Green 1321 C



Pink 1630 C



White 1673 C



Light grey 1707 C



Black 1764 C



Magenta 1834 C



Bright blue 1833 C



Bright yellow 1832 C

5 Drawers

10 Drawers

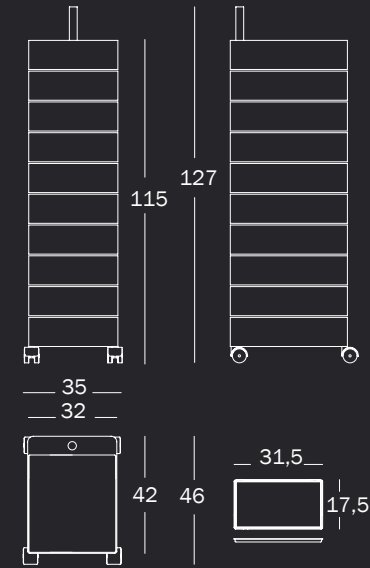
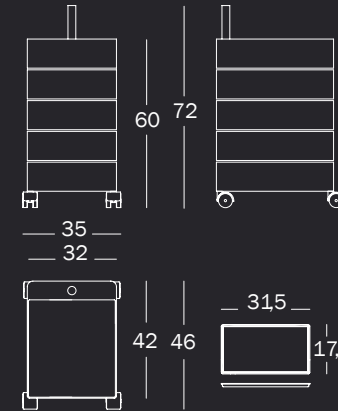

PRODUCT CARE

We recommend using a soft rag, either dry or wet. When needed, use ph-balanced soap diluted in water. Do not use abrasive sponges as they may leave scratches. Avoid using acidic products, solvents and products containing ammonia. Periodic maintenance and cleaning allows the products to keep their original look and lengthens the duration of their performance.

WARNING

Do not use the product in an improper way: do not use different cleaning products from the ones mentioned above; do not place hot objects on it, stand on it or use the product as a ladder. Please avoid overloading the upper drawers and 180° rotating for more than a drawer at a time. Maximum weight allowed for each drawer: 3 kg. Once disused, please make sure that this product is disposed in an environment-friendly way.



